

## Protecta FR Board, Concrete Wall from 75mm Uninsulated Steel, Copper or Alupex Pipe

### Installation Instructions

1. Before installing Protecta® FR Board ensure that the surface of all service penetrations and surrounding construction is free from all loose contaminants, dust and grease.
2. Protecta® FR Coating and Protecta® FR Acrylic are water based, so in cases where corrosion protection is a problem, some metals may require a barrier between the seal and the surface prior to this installation.
3. The board can be positioned to either side of the construction or anywhere in between.
4. Cut the required board(s) to suit the aperture dimensions and type and size of service penetration(s). All exposed and cut edges of the board can be sealed with Protecta® FR Acrylic prior to fitting which will act as an adhesive and ensure a smoke tight seal.
5. The board must be friction fitted or otherwise firmly supported. Then all joints, gaps or imperfections in the installed seal must be filled with Protecta® FR Acrylic on both sides.
6. Protecta® FR Board can be over-painted with most emulsion or alkyd (gloss) paints.

Max aperture  
Unlimited Width x  
1200mm

Steel, Copper  
or Alupex Pipe

1 layer 60mm  
FR Board 2-S

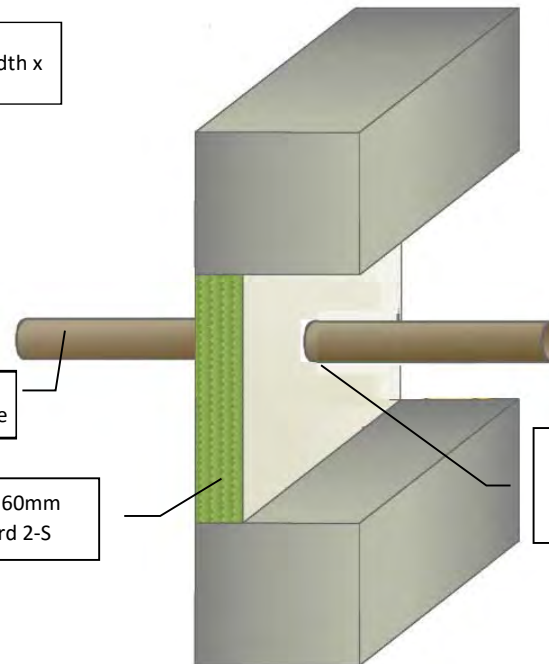

All services and openings  
must be sealed with FR  
Acrylic both sides

Smoke-Safe (<0.1m<sup>3</sup>/h smoke leakage at 200Pa)

### Minimum separations and limitations

An aperture can include several services, and they may also be different. Services within the system Protecta® FR Board seal do not require a minimum separation, except pipes where pipe insulation penetrates the seal and plastic pipe penetrations which should be a minimum of 30 mm from other services in the aperture. Services should be a minimum of 25mm from seal edges. The total amount of cross sections of services (including insulation) should not exceed 60% of the penetration area. The minimum permitted separation between adjacent apertures is 200mm.

System/FPA Register ID# FC351

<b>Products</b>	Protecta FR Board Protecta FR Acrylic
<b>Application</b>	Fire stopping of steel, copper or alupex pipes in rigid walls
<b>Construction</b>	Minimum wall thickness of 75mm and comprise concrete, aerated concrete or masonry, with a density of ≥ 650 kg/m <sup>3</sup>

### Fire & Sound classification

#### Wall Thickness 150mm

Copper or steel pipes ≤ Ø54mm FRR -/240/-

Alupex pipes ≤ Ø75mm FRR -/120/-

Steel pipes ≤ Ø219mm FRR -/240/-

Steel pipes ≤ Ø325mm FRR -/120/-

#### Wall Thickness 75mm

Copper or steel pipes ≤ Ø54mm FRR -/120/-

Alupex pipes ≤ Ø75mm FRR -/120/-

Steel pipes ≤ Ø325mm FRR -/120/-

Sound reduction (seal only) STC 55

As a part of our policy of on-going product development and testing, we reserve the right to modify, alter or change product specifications without giving notice. All information contained in this document is given in good faith and is provided for guidance only. Any drawings provided are for illustrative purposes only. As Polyseam has no control over the methods or competence of installation and of prevailing site conditions, no warranties, expressed or implied, is intended to be given as to the actual performance of the product mentioned or referred to herein and no liability whatsoever will be accepted for any loss, damage or injury arising from the use of the information given.

For all technical details on the products specified please refer to the technical data sheets that can be found on [www.firestopcentre.co.nz](http://www.firestopcentre.co.nz)

Signed and approved:



Sheet size: **A4**  
Drawn date & no: 20/4/21

Scale: **NTS**  
Drawn by: K.B